

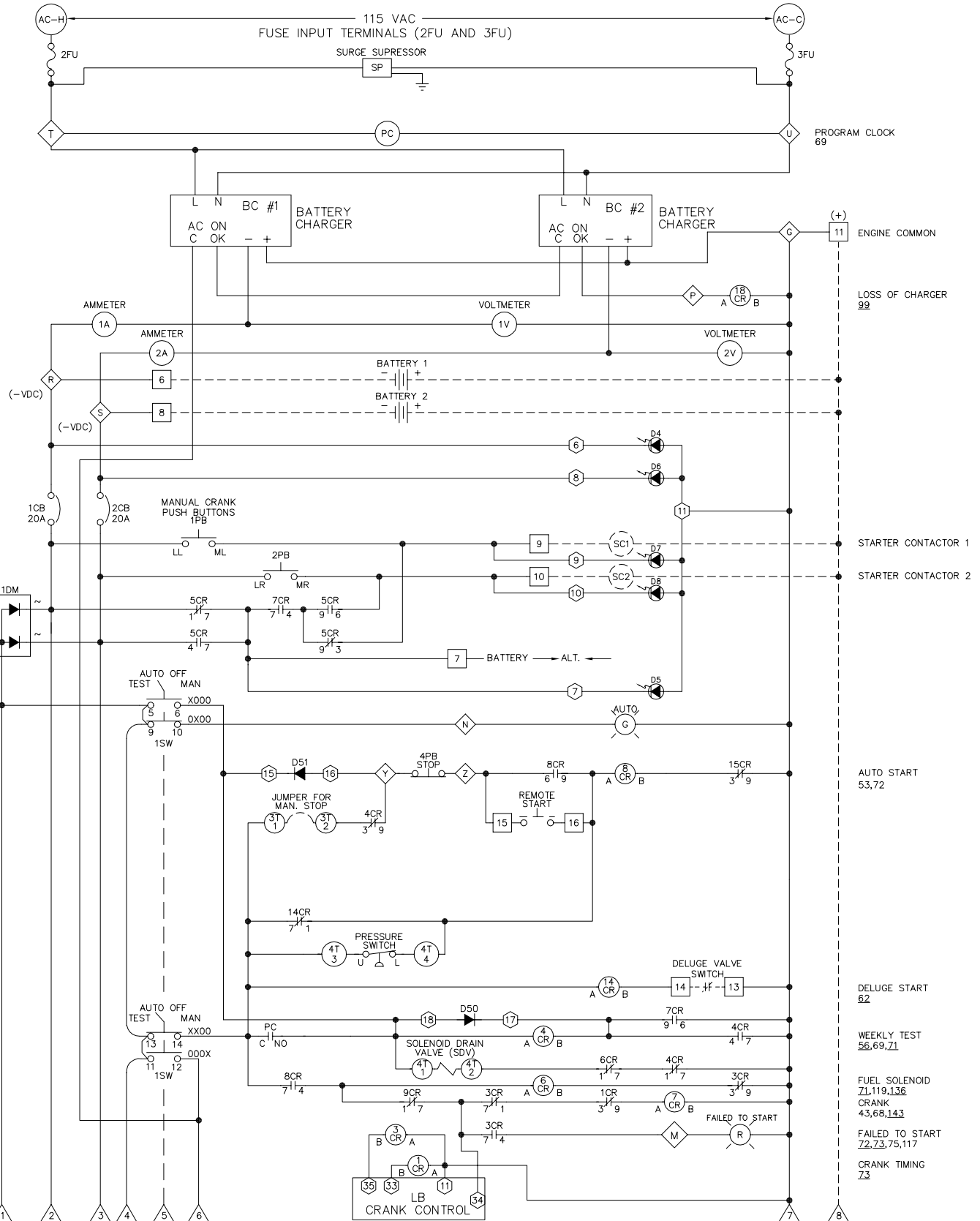

1  
2  
3  
4  
5  
6  
7  
8  
9  
10  
11  
12  
13  
14  
15  
16  
17  
18  
19  
20  
21  
22  
23  
24  
25  
26  
27  
28  
29  
30  
31  
32  
33  
34  
35  
36  
37  
38  
39  
40  
41  
42  
43  
44  
45  
46  
47  
48  
49  
50  
51  
52  
53  
54  
55  
56  
57  
58  
59  
60  
61  
62  
63  
64  
65  
66  
67  
68  
69  
70  
71  
72  
73  
74  
75  
76  
77  
78  
79  
80



- NOTES:
- - DENOTES TERMINALS ON 1T LOCATED AT FRONT BOTTOM OF RELAY PANEL.
  - ◇ - DENOTES TERMINALS ON 2T LOCATED AT FRONT TOP OF RELAY PANEL.
  - ⊙ - DENOTES TERMINALS ON 3T LOCATED AT CENTER OF RELAY PANEL.
  - ⊕ - DENOTES TERMINALS ON 4T LOCATED AT FRONT BOTTOM OF RELAY PANEL.

NOTES:

THERE IS A DIODE AND RESISTOR IN SERIES WITH EACH LED, NOT SHOWN ON SCHEMATIC.

DRAWN	SR	2-12-99	 <b>METRON, INC.</b> DENVER, CO.
CHECK	KH	2-12-99	
APPD	J.C.	2-12-99	
SCHEMATIC MODEL FD2, POSITIVE GROUND ENGINE DRIVEN FIRE PUMP CONTROLLER			OPTIONS: CS33285C
SCALE N.T.S.			SHEET 1 OF 2